

高端立式混色机

HIGH-END VERTICAL COLOR MIXING MACHINE



方型下料口
Square unloading port
标准为拉丝面加厚不锈钢, 可定制镜面
standard brushed surface and thickened
stainless steel, mirror surface can be customized



圆型下料口
Round discharge opening
高端型搅拌机下料口分为方口和圆口两种,
两种下料口都是最新型设计都不会卡料
The discharge opening of high-end mixers is
divided into two types, square opening and
round opening. Both feeding openings are of the
latest design and will not jam materials.

桨叶
Paddle

机器特点 >>

1. 采用进口不锈钢材料制作, 高强度耐用及清洗方便。
2. 垂直减速马达, 确保噪音低及持久耐用。
3. 结构科学, 合理, 混合能力强, 3分钟内可充分提搓原料。
4. 占地面积少, 脚轮装置移动方便。
5. 附有安全保护开关, 操作绝对安全。

1. Made with import stainless steel, high strength of durable and cleaning convenient.
2. Vertical geared motor ensuring the mixer low noise and durable.
3. Structure of scientific rational, mixed ability, fully stirring raw materials in 3 minutes.
4. Covers less area, casters device convenient movement.
5. Cover with a safety switch, the operation is absolutely safe.

机器特点 >>

1. 四轮直立式设计, 产品体积小, 便于移动。
2. 螺旋循环搅拌使得原料混合更加均匀、快速。
3. 设备与原料所接触部分的材料皆为全不锈钢制作, 清洗容易, 避免锈蚀。
4. 适用于各种塑料原料与色母的混合搅拌, 新、旧料及色母混合则效果更佳。
5. 运用理想的摆线针减速电机与搅拌机直接连接, 用料搅拌均匀, 桨叶可取出并便于清理。
6. 配备交流接触器, 具有电控过热安全保护装置。

1. Four-wheel vertical design, small volume, easy to move
2. spiral circulation stirring enables the raw materials to be mixed more evenly and quickly
3. The materials of the parts contacted by the equipment and the raw materials are all stainless steel. Easy cleaning to avoid rust.
4. It is suitable for mixing and purchasing various materials and color masterbatch. The mixture of material and color masterbatch has better effect.
5. Use ideal cycloid needle reduction motor to directly return mix the materials evenly so that the pulp leaves can be taken out and cleaned easily.
6. equipped with AC contactor, with electricity overheating safety protection.

基本结构说明 >>

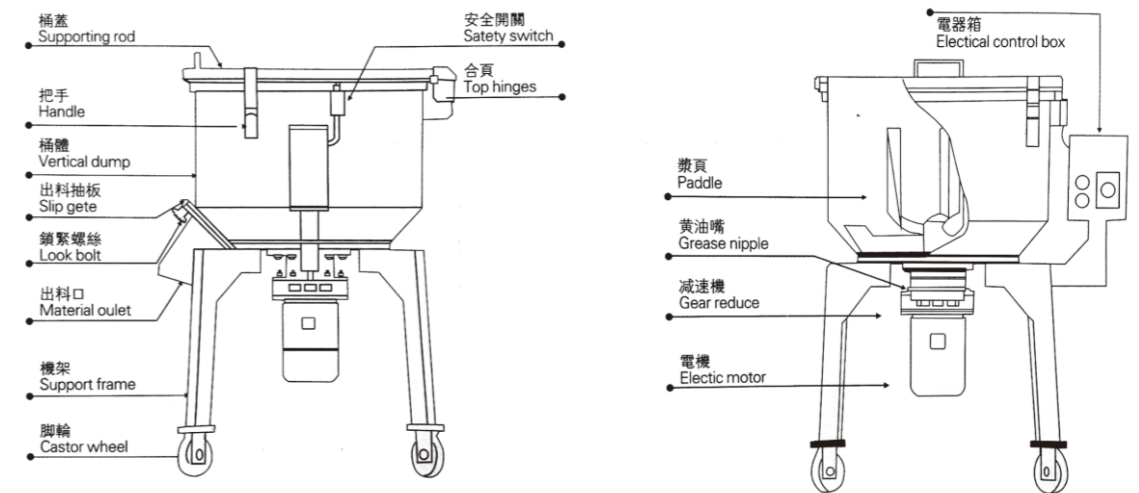

技术参数 TECHNICAL PARAMETER

型号 Model (KG)	25	50	100	150	200	300	500
电压 (V/Hz) Voltage	380V/50HZ						
功率 (KW) Power	0.75	1.5	3	4	5.5	7.5	11
混合量 (KG) Mixing quantity	25	50	100	150	200	300	500
外形尺寸 (米) Dimension	0.73x0.7x0.88	0.85x0.82x1.04	0.98x0.88x1.23	1.1x1x1.23	1.23x1.15x1.33	1.32x1.22x1.53	1.73x1.62x1.65
桶体内径*高度 (MM) Inside diameter * height	500x400	620x440	750x560	880x610	1000x660	1100x820	1500x800
脚架高度 (MM) Height of scaffold	480(含脚轮) With casters	550(含脚轮) With casters	630(含脚轮) With casters	550(不含脚轮) Does not include casters	550(不含脚轮) Does not include casters	670(不含脚轮) Does not include casters	820(不含脚轮) Does not include casters
转速 (R/Min) Speed	63	63	63	63	63	63	63
桶壁厚 (MM) Barrel wall thickness	1.5	1.5	1.5	2	2	2	2.5
桨叶厚度*宽度 (MM) Blade thickness x width	8x50	8x50	8x60	12x60	12x60	12x60	12x60
铁底板厚度 (MM) Thickness of iron base plate	10	10	10	12	12	12	12
机器重量 (KG) Weight	90	90	126	163	228	262	460

产品规格参数如有变动, 恕不另行通知。
Specifications are subject to change without notice.